



THE HEART OF YOUR HOME



MULTIFUEL • WOOD • GAS

STOVES

2018 COLLECTION



THE HEART OF YOUR HOME



WELCOME

AT FLAVEL STOVES WE KNOW HOW IMPORTANT IT IS
TO CREATE A STYLISH AND RELAXING LIVING ENVIRONMENT

That's why we've developed this collection of multifuel, gas and wood burning stoves to complement all tastes and lifestyles. I believe our success stems from a combination of innovative design, investment in technology and the highest quality manufacturing standards.

As a result I have total confidence and belief in the quality and durability of the product range, and to ensure you receive the very best advice and after sales service, our experienced Flavel retailers are fully trained to assist you with your purchase. This brochure has been designed to make choosing your new Flavel stove as simple as possible. I hope you will find it both informative and inspiring.



BFMEurope
BRITISH FIRE MANUFACTURERS

Today BFM Europe is the fastest growing domestic fire and stove producers in the country with an unequalled reputation for quality and service.

CONTENTS



INTRODUCTION

4 - 5

Your peace of mind	4
Traditionally well built stoves features at a glance	5



SOLID FUEL STOVES

6 - 25

Introduction	6-7
Arundel XL	8-9
Arundel.....	10-11
Dalton.....	12-13
Rochester 5	14-15
Rochester 7	16-17
No.1 SQ05.....	18-19
No.1 CV05.....	20-21
No.2 SQ07	22-23
No.2 CV07.....	24-25



GAS STOVES

26 - 29

Introduction	26-27
No.1	28-29

STOVE DIMENSIONS

30 - 31

YOUR PEACE OF MIND



TESTED & APPROVED

All Flavel stoves carry independently tested CE Approval to standard BS EN 13240 or BS EN 13229, with many approved by HETAS, the official body recognised by Government to approve solid fuel heating appliances.

We always recommend you use an experienced HETAS approved installer to fit your stove. To learn more about HETAS and find details of HETAS registered installers visit www.hetas.co.uk



PRODUCT TESTING & CERTIFICATION

Our Gas stoves are independently tested, approved and verified by the British Standards Institution (BSI).

The BSI is an independent organisation and are internationally recognised for their technical expertise, quality services and in-depth knowledge of gas and electrical testing certification.

The wide-ranging capability of their testing facilities and the broad expertise and knowledge of their staff ensures our products are rigorously tested with the utmost integrity.



CLEAN BURNING STOVES

Products which carry independently tested CE Approval to standard BS EN 13240 are so efficient and clean burning they have received DEFRA's recommendation for exemption from the Clean Air Act 1993.

Flavel stoves which carry this symbol can be used in Smoke Control Areas when burning wood, as well as authorised smokeless fuels. They can also be used in smoke free zones in the Republic of Ireland when burning wood or peat briquettes.



ECODESIGN COMPLIANT

This logo signifies that Flavel gas products are fully compliant with the Eco design directive Commission Regulation (EU) 2015/1188.



2022 EU CLEAN STOVE STANDARD

Our EU Clean Stove ready products comply with the exceptional 2022 EU standards set to improve the environment by producing highly efficient stoves, that offer clean burning, with ultra-low emissions.



FLAVEL 5 YEAR GUARANTEE

Solid Fuel Stoves

Every Multifuel or Wood Burning stove carries the peace of mind of a 5 year guarantee against material and manufacturing defects on the stove body.

Cast iron parts are guaranteed for 2 years. Consumable components and glass parts are guaranteed for a period of 1 year against material and manufacturing defects, and are subject to the terms and conditions as specified in the guarantee document supplied with the product.

Gas Stoves

Gas stoves carry a 5 year guarantee against manufacturing and material defects including parts and labour, and is subject to Flavels' conditions of guarantee. These include an annual service and annual replacement of the oxypilot assembly.

TRADITIONALLY WELL BUILT STOVES

FLAVEL HAS PLENTY TO OFFER WHEN IT COMES TO STOVE BUILD QUALITY.
SIMPLY PUT, OUR STOVES ARE BUILT TO LAST.

Sourcing only the best materials is imperative when it comes to forming a solid stove structure made to withstand extremely high temperatures, providing years of fuel burning heat throughout your home. Our steel bodied stoves are 5mm thick, and integrate with the finest quality cast iron components to thermally conduct high energy heat transfer steadily throughout the stove.

Our range of slim depth models allow for easy installation into existing fireplaces without the need for a protruding hearth. Flavel stoves also provide good fuel capacity creating a slow burn, consistent heat release for over ten hours based on a single filling of natural anthracite or other suitable fuel.

Aesthetically you can expect Flavel stoves to deliver charm and character fitting in nicely with today's mix of home interiors. Whether you have a rustically styled country home, or you live in a more modern town or city property, the Flavel stove collection has a solid fuel, or gas stove appliance designed and created with function and reliability that forms a unique centrepiece at the heart of your home.

All stoves need air to breathe. There must be a permanent fresh air supply into the space in which it is installed equal to 550mm for each kW of nominal output. This can often be provided by natural drafts or air leaking around door frames etc. It is commonly accepted that this alone may suffice for appliances up to 5kW, but if in doubt fit a purpose-made air vent. Consult with your HETAS installer for more advice on adequate ventilation and the requirements of a Carbon Monoxide monitor.



SOLID FUEL STOVE FEATURES

Heat direction

Multifuel stove interiors are lined with high density vermiculite insulation, preventing heat loss to the rear and side panels whilst directing heat forwards towards the front and centre of the room.

Woodstove interiors have the advantage of an insulated vermiculite base, this keeps the bottom of the stove extremely hot and ensures highly efficient wood burn with very little ash.

You're in control

Simple and reliable controls that perform exceptionally well, provide a simple user friendly experience that offers great temperature control, leading to sensible fuel efficiency.

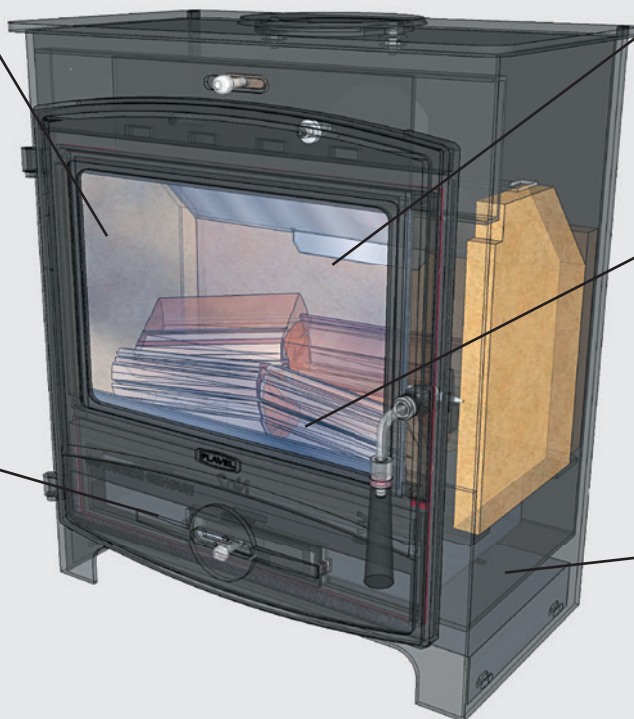

A generous display

Large stove windows allow a generous and perfect view of the lively fuel bed area, framing a captivating display of burning fuel with natural random flame movements.

Clear views ahead

To keep the stove windows clean and free from the build-up of combustion soot particles, a pre-heated Airwash system maintains a stream of hot air down the inside of the glass preventing flames from having contact with the window.

Ashpan convenience

Multifuel stoves include an easy access ash collection tray. A simple and easy solution to contain gathered ash for disposal.



GAS STOVE FEATURES

There's no greater convenience than the instant push button controllability of a gas fire built directly into a steel bodied stove.

ALL THE BENEFITS OF GAS

- Flavel gas fire engineering
- Immediate and Instant heat
- Impressive energy efficiency
- Fully automatic thermostatic remote control system
- Realistic log effect fuel bed



SOLID FUEL STOVES

THE NATURAL CHOICE

A FORCE OF NATURE



Harnessing the power of nature by burning natural fuels, Flavel's range of multifuel and wood burning stoves are dependable, clean burning appliances designed to provide your home with an effective controllable level of heat.

The benefits of running a solid fuel stove are numerous.



ENVIRONMENTAL SENSE

Burning wood is friendly to the environment. Choosing wood to heat our homes helps us to preserve fossil fuel levels and protect valuable earth resources for our future. Replanted trees grown for fuel provide a healthy self-sustaining fuel source, and a positive way to reduce CO2 emissions that are harmful to the environment. Using two year old seasoned wood will increase heat output. New timber is not recommended as it carries excessive moisture and can produce unwanted smoke emissions.



NATURALLY EFFICIENT

Flavel's R&D team has invested in developing and refining technology to meet the key objective of producing stoves that not only save energy but, as a result, keep running costs down. All our stoves carry a Class A rating with energy efficiencies of up to 78.8%.

To achieve the cleanest burn time with maximum efficiency performance we recommend burning natural hard wood logs, and manufactured approved smokeless fuels. Flavel Multifuel stoves can also burn a wide range of other fuels including anthracite, peat briquettes, and other mineral fuels.



GENUINE WARMTH

Flavel multifuel and wood burning stoves will provide you with warmth like no other energy source. Every burn period produces long lasting radiant heat that will maintain your comfort levels whilst returning high efficiency with low emissions when burning natural and renewable fuels. Our stoves can easily burn for ten hours or more in a single filling of natural anthracite or other suitable fuel. This means you burn less fuel to get more heat compared to similar products on the market.



ARUNDEL XL

MULTIFUEL STOVE

The Flavel Arundel XL Multifuel stove is a large proportioned version of the Arundel Multifuel stove. It makes an instant impact with its striking extra large viewing window, contemporary styling and contrast polished silver handle. This hard working steel bodied stove features a cast iron door and a log retaining grate bar that, although part of the functionality of the stove, enhances its overall aesthetics. Incorporating high efficiency Flavel stove technology this large Class A appliance attains a heat output of up to 4.9kW.



FEATURES

- Simple Primary and Secondary air controls
- Tertiary air supply
- Strong steel body
- Cast iron door
- Externally controllable riddle system
- Very large viewing window
- Radiant heat output
- CE approval to BS EN 13240:2001+A2:2004
- Suitable for use in Smoke Control Areas
- Takes log lengths up to 250mm/10"
- 125mm (5") top or rear flue connection
- Weight 86kg

SPECIFICATIONS

- Energy Class **A**
- Useful Energy Efficiency **78.1%**
- Fuel Type **Multifuel**
- Direct Heat Output **4.9kW**
- Model Number **FCMSBXL**



WATCH A VIDEO





ARUNDEL

MULTIFUEL STOVE

The Flavel Arundel Multifuel Stove has been developed with aesthetics, efficiency and flexibility in mind. This steel bodied stove's robust looks and large viewing window makes it suitable for most room settings. The Flavel Arundel has a heat output of 4.9kW and an energy efficiency of 76.3% allowing it to be both cost effective and heat efficient. The Arundel is suitable for use in Smoke Control Areas, as recommended by DEFRA.



FEATURES

- Simple Primary and Secondary air controls
- Tertiary air supply
- Strong Steel body and door
- Externally controllable riddle system
- Large viewing window
- Radiant heat output
- Certified to BE EN 13240
- Suitable for use in Smoke Control Areas
- Takes log lengths up to 250mm/10"
- 125mm (5") top or rear flue connection
- Weight 70kg

SPECIFICATIONS

- Energy Class **A**
- Useful Energy Efficiency **76.3%**
- Fuel Type **Multifuel**
- Direct Heat Output **4.9kW**
- Model Number **FCMSB2**



WATCH A VIDEO





DALTON

MULTIFUEL STOVE

The Flavel Dalton Multifuel stove is a compact, intelligent stove with patented cast steel construction. The Dalton boasts an incredibly simple and fast control system as well as an easy ash collection for stress-free maintenance. Despite its petite proportions The Dalton achieves a heat output of 4.9kW and an energy efficiency of 78.8%. For its size this stove certainly packs a powerful punch!



FEATURES

- Patented cast steel construction
- Clean glass Airwash system
- Primary and Secondary air control
- Adjustable legs
- Easy, fast control system
- Simple Ash Collection
- Ultra-Slim depth
- CE approval to BS EN 13240:2001+A2:2004
- Suitable for use in Smoke Control Areas
- Takes log lengths up to 250mm/10"
- 125mm (5") top or rear flue connection
- Weight 68kg

SPECIFICATIONS

- Energy Class **A**
- Useful Energy Efficiency **78.8%**
- Fuel Type **Multifuel**
- Direct Heat Output **4.9kW**
- Model Number **FN1MFD**

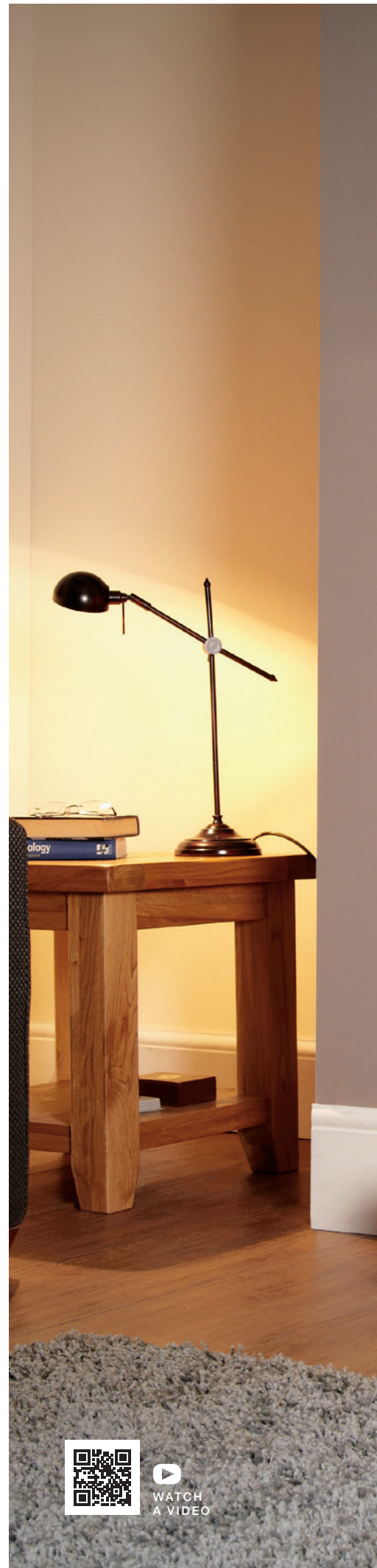

WATCH A VIDEO





ROCHESTER 5

MULTIFUEL STOVE

The Flavel Rochester 5 Multifuel stove is elegantly styled with an attractive top cornice and a contrast polished silver trim and handle. It is also available in a black door trim option.

The classical appearance of this stove is also enhanced by the beautiful cast iron door, stove top and base. Its petite proportions are perfect for small to medium sized rooms and a 4.9kW heat output presents a highly efficient source of heating.



FEATURES

- Strong steel body with cast iron door, top and feet
- Large viewing window
- Simple primary and secondary air controls
- Externally controllable riddle system
- Radiant heat output
- CE approval to BS EN 13240:2001+A2:2004
- Suitable for use in Smoke Control Areas, as recommended by DEFRA
- Alternative silver door trim available
- Takes log lengths up to 250mm/10"
- 125mm (5") top or rear flue connection
- Weight 75kg

SPECIFICATIONS

- Energy Class **A**
- Useful Energy Efficiency **78.5%**
- Fuel Type **Multifuel**
- Direct Heat Output **4.9kW**
- Model Number **FCSSB5**
- Back Door Trim **FCSSB5B**

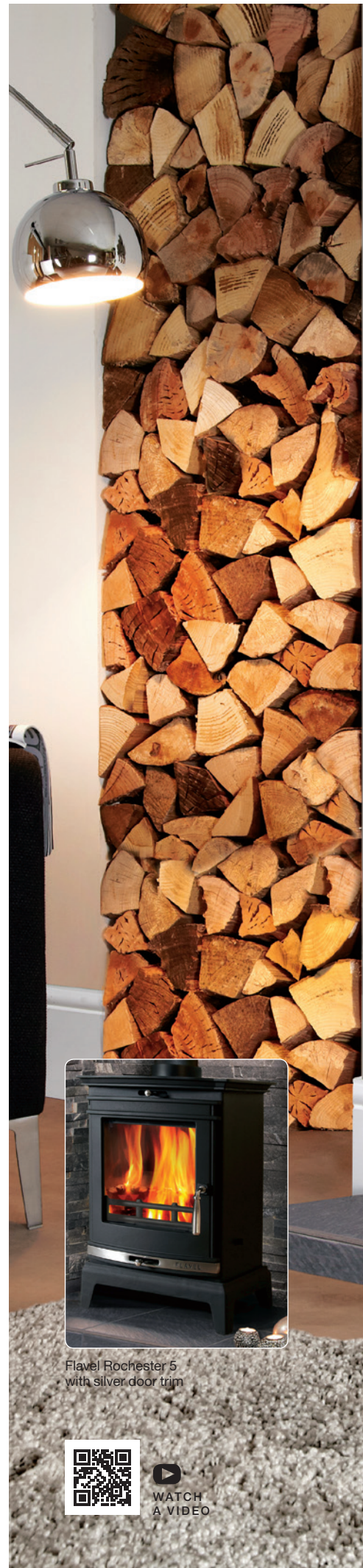

Flavel Rochester 5 with silver door trim



WATCH A VIDEO





ROCHESTER 7

MULTIFUEL STOVE

The Flavel Rochester 7 Multifuel stove is a larger model than its sibling the Rochester 5, boasting all the same features and benefits with increased efficiencies. Its modern day classic styling and large viewing window allow you to enjoy all the benefits of its warmth and good looks. It features a stylish polished silver trim detail, or it can be specified with a black door trim option to match the body. This powerful stove has an impressive heat output of 7.0kW making it an attractive option for medium to large sized rooms.



FEATURES

- Strong steel body with cast iron door, top and feet
- Large viewing window
- Simple primary and secondary air controls
- Externally controllable riddle system
- Radiant heat output
- CE approval to BS EN 13240:2001+A2:2004
- Suitable for use in Smoke Control Areas, as recommended by DEFRA
- Alternative black door trim available
- Takes log lengths up to 250mm/10"
- 125mm (5") top or rear flue connection
- Weight 93kg

OPTIONAL EXTRAS

Output reducing bricks. To reduce heat output to 5kW

SPECIFICATIONS

- Energy Class **A**
- Useful Energy Efficiency **74.1%**
- Fuel Type **Multifuel**
- Direct Heat Output **7.0kW**
- With reducing bricks **5.0kW**
- Model Number
Silver door trim FCSSB
Black door trim FCSSBB
- Reducer Brick Kit
1170-183610



Flavel Rochester 7 with black door trim



WATCH A VIDEO





No. 1

SQ05

MULTIFUEL STOVE

The Flavel No 1 SQ05 Multifuel stove has a distinct appearance with its clean lines and simple, but stylish design features. It can be installed into a wide variety of fireplaces due to its ultra slim body and into practically any room setting as a result of its versatile timeless design. The Flavel No. 1 can achieve a heat output of up to 4.9kW.



FEATURES

- 5mm thick steel bodies
- Cast iron doors and grates
- Large viewing window
- Simple operating controls
- Ultra-slim depth
- Clean glass Airwash system
- Large, easy-carry ashpan
- CE approval to BS EN 13240:2001+A2:2004
- Suitable for use in Smoke Control Areas
- Takes log lengths up to 300mm/12"
- 125mm (5") top or rear flue connection
- Weight 56kg

OPTIONAL EXTRAS

Direct Vent Kit. To draw the correct amount of ventilation directly to the stove without the need for a draughty and unsightly airbrick

SPECIFICATIONS

- Energy Class **A**
- Useful Energy Efficiency **78.8%**
- Fuel Type **Multifuel**
- Direct Heat Output **4.9kW**
- Model Number **SQ05 FN1MFBT**
- Direct Vent Kit **PSAK**



WATCH A VIDEO





No. 1

CV05

MULTIFUEL STOVE

The Flavel No. 1 CV05 is a compact, multifuel steel bodied stove, with simple good looks to suit a wide variety of room settings. It has an ultra-slim body to allow it to be installed into a wide range of fireplaces. The CV05 option features a modern curved design.

The Flavel No. 1 can achieve a heat output of up to 4.9kW.



FEATURES

- 5mm thick steel bodies
- Cast iron doors and grates
- Large viewing window
- Simple operating controls
- Ultra-slim depth
- Clean glass Airwash system
- Large, easy-carry ashpan
- CE approval to BS EN 13240:2001+A2:2004
- Suitable for use in Smoke Control Areas
- Takes log lengths up to 300mm/12"
- 125mm (5") top or rear flue connection
- Weight 56kg

OPTIONAL EXTRAS

Direct Vent Kit. To draw the correct amount of ventilation directly to the stove without the need for a draughty and unsightly airbrick

SPECIFICATIONS

- Energy Class **A**
- Useful Energy Efficiency **78.8%**
- Fuel Type **Multifuel**
- Direct Heat Output **4.9kW**
- Model Number **CV05 FN1MFB**
- Direct Vent Kit **PSAK**

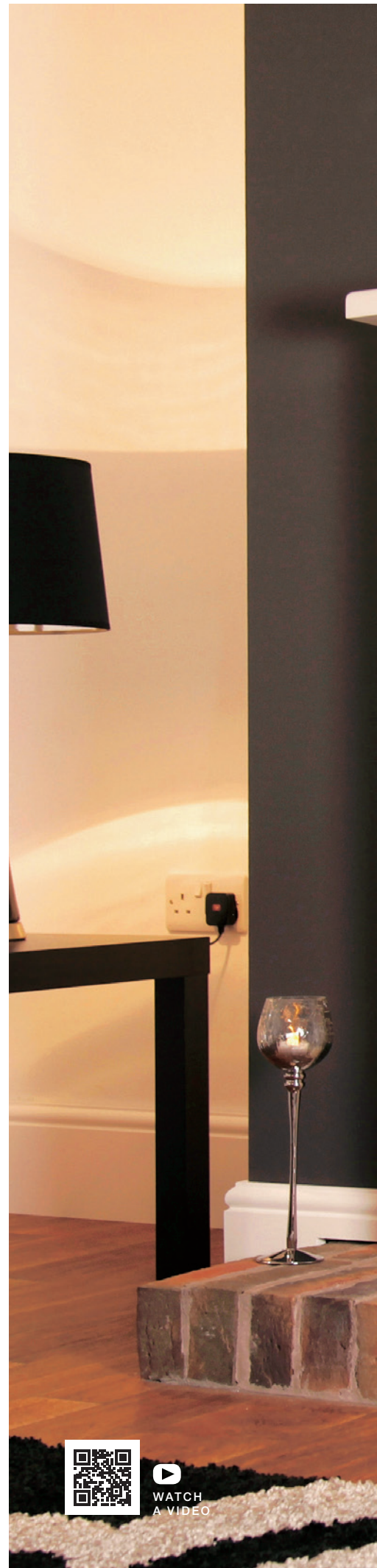

WATCH A VIDEO





No. 2

SQ07

MULTIFUEL STOVE

The Flavel No. 2 SQ07 Multifuel stove is a classically designed stove featuring a large square viewing window that reveals a beautiful fuel bed and flame pattern. Its simple good looks make it suitable for installation into a wide range of interiors. This quality steel bodied stove is exceptionally easy to operate and is capable of burning for up to 10 hours on a single filling, providing a heat output of up to 6.9kW which makes it a great option for larger rooms.



FEATURES

- 5mm thick steel bodies
- Cast iron doors and grates
- Large viewing window
- Simple operating controls
- Ultra-slim depth
- Clean glass Airwash system
- Large, easy-carry ashpan
- Heat output reducer bricks to convert to 5kW
- CE approval to BS EN 13240:2001+A2:2004
- Suitable for use in Smoke Control Areas
- Takes log lengths up to 410mm (16")
- 125mm (5") top or rear flue connection
- Weight 68kg
- Ventilation required 110mm²

OPTIONAL EXTRAS

- Output reducing bricks. To reduce heat output to 5kW
- Direct Vent Kit. To draw the correct amount of ventilation directly to the stove without the need for a draughty and unsightly airbrick

SPECIFICATIONS

- Energy Class **A**
- Useful Energy Efficiency **78.2%**
- Fuel Type **Multifuel**
- Direct Heat Output **6.9kW**
- With Reducing Bricks **5.0kW**
- Model Number **SQ07 FN1MFBT**
- Reducer Brick Kit **1135-172500**
- Direct Vent Kit **PSAK**



WATCH A VIDEO





No. 2

CV07

MULTIFUEL STOVE

The Flavel No. 2 CV07 Multifuel stove with its clean lines and design style make it a versatile option for contemporary, classic or traditional homes. Built from high quality steel and featuring a large curved viewing window to give you maximum enjoyment of the flames and the fuel bed. This stove is exceptionally easy to operate and is capable of burning for up to 10 hours on a single filling, providing a heat output of up to 6.9kW, ideal for the efficient heating of larger rooms.



FEATURES

- 5mm thick steel bodies
- Cast iron doors and grates
- Large viewing window
- Simple operating controls
- Ultra-slim depth
- Clean glass Airwash system
- Large, easy-carry ashpan
- Heat output reducer bricks to convert to 5kW
- CE approval to BS EN 13240:2001+A2:2004
- Suitable for use in Smoke Control Areas
- Takes log lengths up to 410mm (16")
- 125mm (5") top or rear flue connection
- Weight 68kg
- Ventilation required 110mm²

OPTIONAL EXTRAS

- Output reducing bricks. To reduce heat output to 5kW
- Direct Vent Kit. To draw the correct amount of ventilation directly to the stove without the need for a draughty and unsightly airbrick

SPECIFICATIONS

- Energy Class **A**
- Useful Energy Efficiency **78.2%**
- Fuel Type **Multifuel**
- Direct Heat Output **6.9kW**
- With Reducing Bricks **5.0kW**
- Model Number **CV07 FN1MFB**
- Reducer Brick Kit **1135-172500**
- Direct Vent Kit **PSAK**



WATCH A VIDEO



A black gas stove is the central focus, set within a white fireplace mantel. The stove has a glass door showing a fire burning inside. A black chimney pipe extends from the top of the stove. The fireplace is built on a brick hearth. The background wall is dark, and a framed picture hangs above the mantel.

GAS STOVES

THE ENLIGHTENED CHOICE

WISELY CONVENIENT



For immediate warmth and comfort a Flavel gas stove will fit right into your busy lifestyle providing instant heat with no mess, no fuss and no reloading of fuel. At the push of a button you can instantly create a warm and welcoming atmosphere.



EASY TO USE

Controllability with convenience. Fuss free with no mess. Just a few of the many advantages of installing a High Efficiency gas stove from Flavel. Operated by a fully automatic remote control handset, you set the temperature you want in your room whilst enjoying a highly realistic log fuel bed and flame pattern giving the look and feel of a real wood burning stove. Simple.



EFFICIENCY

Our R & D team continually develop gas technology to both achieve the highest possible efficiency standards.

Our gas stoves are designed for simple installation into homes with or without a conventional chimney or flue, and can achieve impressive energy efficiencies of up to 84.2%.

Flavel is a brand with heritage and a reputation for the build quality and reliability of our appliances. We have always had a reputation as a manufacturer of some of the most efficient gas fires on the market and now we are setting new industry standards with the Flavel range of High Efficiency gas stoves – exceptional heat output combined with lower running costs compared to standard gas stoves.



SAFETY

Your safety is our concern. All Flavel products undergo rigorous testing and certification designed to both meet and exceed current legislation and, more importantly, to give you complete peace of mind.

Our stoves are independently tested, approved and verified by the British Standards Institution (BSI) an independent testing authority recognised internationally for their technical expertise, quality services and in-depth knowledge of gas testing and certification.

In addition, our stoves carry independently tested CE Approval to standard BS EN 13240 or BS EN 13229 and are fully compliant with the Eco design directive Commission Regulation (EI) 2015/1188.

See page 5 for more information.



No. 1

GAS STOVE

The Flavel Gas No1 stove is one of the most realistic gas fuelled stoves on the market. It comes with an extremely realistic log fuel bed and is operated by a fully automatic control system. At the push of a button you can instantly create a warm and welcoming atmosphere. The Flavel Gas stove is suitable for conventional installation into standard brick chimneys and pre-fabricated flues, and also available as a balanced flue option.



FEATURES

- Large flame viewing window
- Choice of realistic log or coal fuel bed
- 5mm thick steel bodies
- Cast iron doors
- Stylish chrome handle
- High quality black painted finish
- Fully automatic remote control
- Instant heat

OPTIONAL EXTRAS

- Coal effect fuel bed (Conventional flue only)
- 830mm flue extension (Balanced flue only)
- Matt black flue collar & 300mm (12") flue pipe (Balanced flue only)

SPECIFICATIONS

Conventional Flue

Energy Class
D

Useful Energy Efficiency
81.4%

Fuel Type
Gas

Direct Heat Output
4.2kW

Model Number
FGSL01RN2

Balanced Flue

Energy Class
C

Useful Energy Efficiency
84.2%

Fuel Type
Gas

Direct Heat Output
3.4kW

Model Number
FBFL00RN



Ecodesign
Compliant



WATCH
A VIDEO

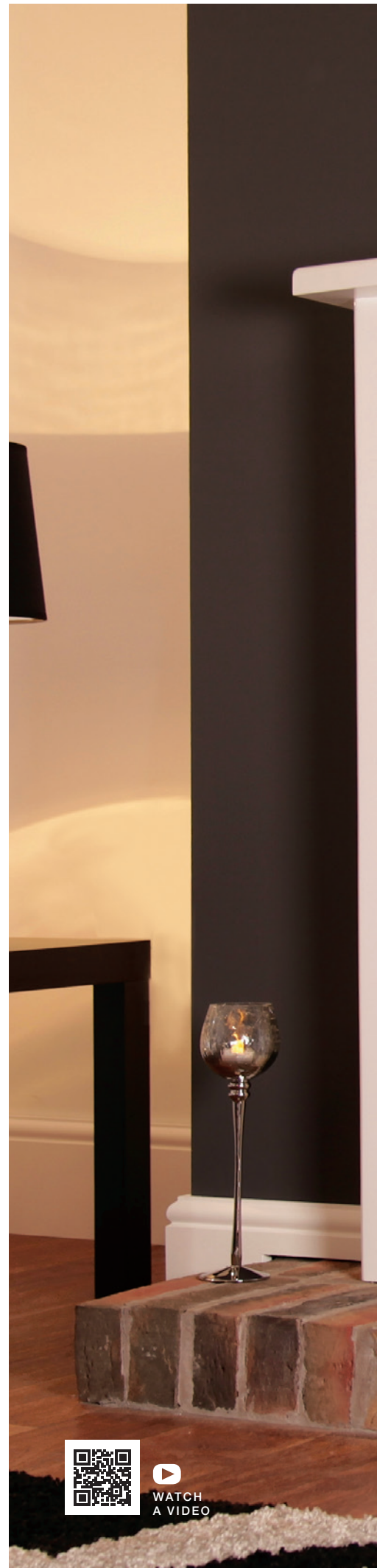



STOVE DIMENSIONS



MULTIFUEL STOVES

Arundel XL – Pages 10-11

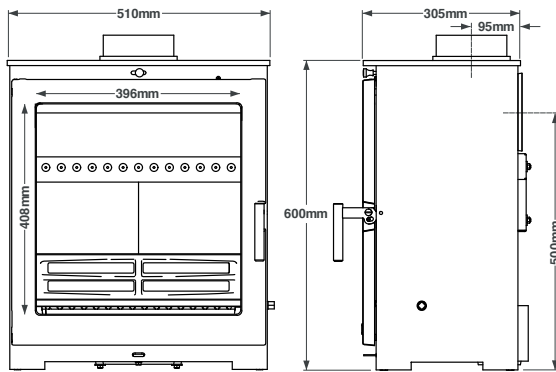

Arundel – Pages 12-13

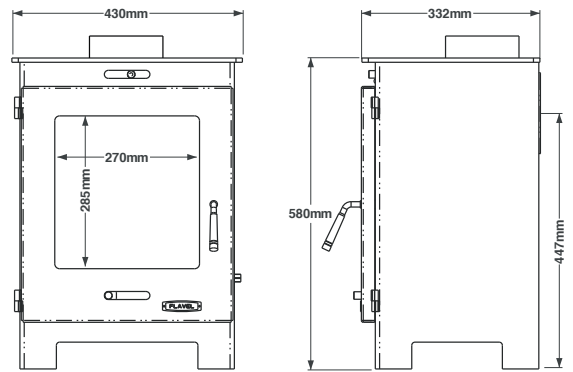

Dalton – Pages 14-15

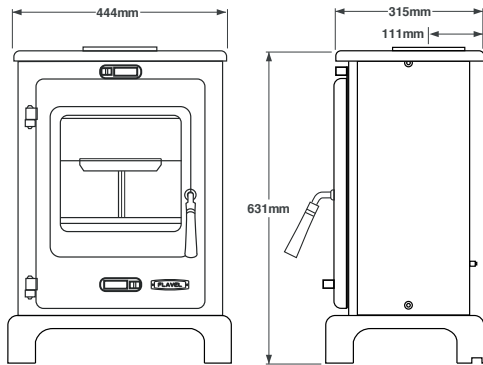

Rochester 5 – Pages 16-17

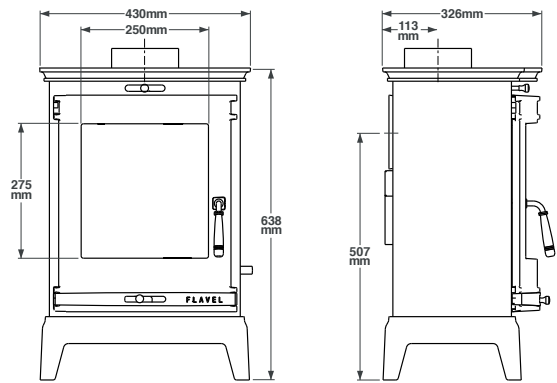

Rochester 7 – Pages 18-19

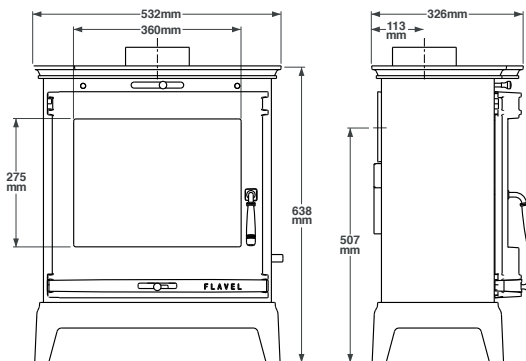

No.1 SQ05 – Pages 20-21

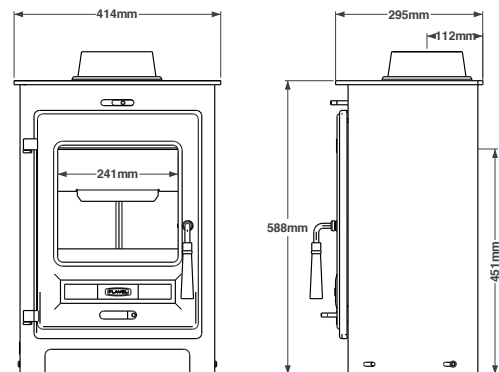

No.1 CV05 – Pages 22-23

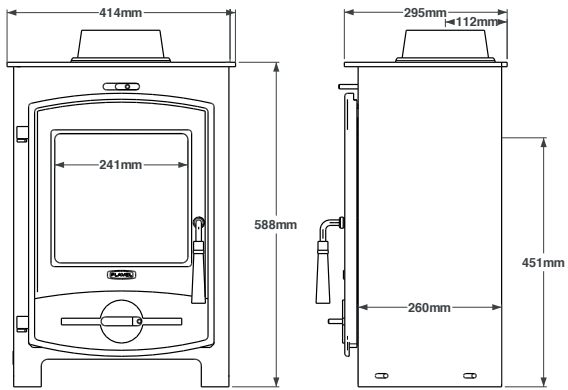

No.2 SQ07 – Pages 24-25

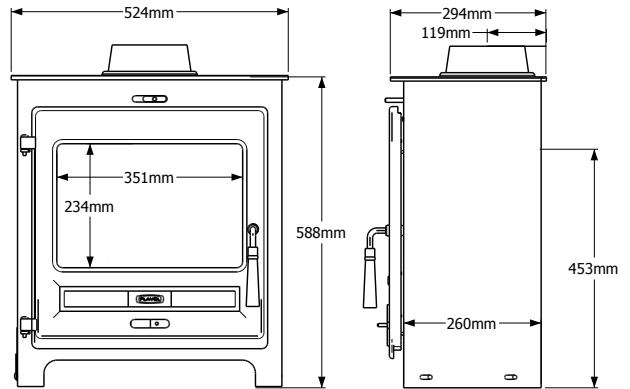

No.2 CV07 – Pages 26-27

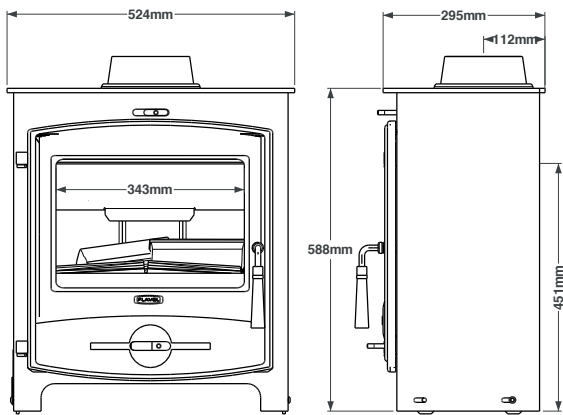

GAS STOVES

No.1 Conventional Flue – Pages 28-29

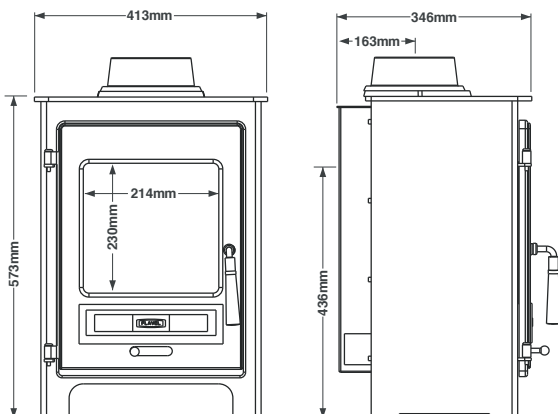

No.1 Balanced Flue – Pages 28-29

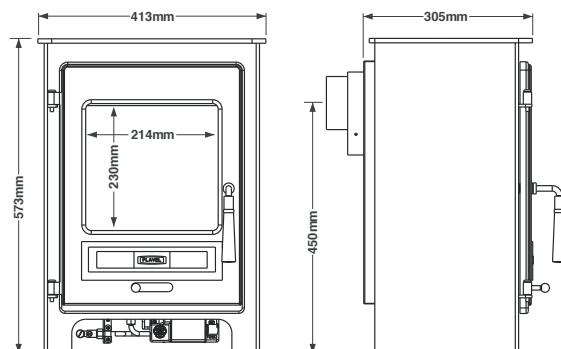



THE HEART OF YOUR HOME



www.flavelfires.co.uk

Go direct to the Flavel website
on your mobile device, scan the QR code.

We would like to thank OER Fireplaces (01782 319350) for
supplying the fire surround and beams used in this brochure.

DISCLAIMER Our policy is one of constant development and improvement. We therefore reserve the right to revise designs and specifications of our products without formal notice, patents pending. We always recommend our products be viewed in an approved showroom before purchase. Whilst we have taken every care in the preparation of this brochure it is not intended to replace the installation manual which provides more detailed information. Photography is for illustration purposes only and although every effort has been made to ensure accurate reproduction of typical installations and flame pictures they may vary according to fuel type and installation. We accept no liability for any loss or damage arising directly or indirectly from the use of this brochure. We recommend that all our fires are used in conjunction with central heating and not as a primary source of heat. In the interests of personal safety a suitable fireguard is recommended when children, the elderly and the infirm are present. (This brochure is copyright 2018 and must not be reproduced in whole or in any part without prior written permission).



Find us on Facebook,
Twitter, Pinterest & YouTube

BFM Europe Limited, Trentham Lakes, Stoke-on-Trent, Staffordshire ST4 4TJ.
Tel: 01782 339000. www.flavelfires.co.uk e-mail: info@bfm-europe.com

ISSUE NO. 7

